

PEX 8111 Key Features

- ◆ Small Package Size
 - 10x10mm Fine-Pitch BGA
 - 13x13mm Std-Pitch BGA
- ◆ Low Power (400mW)
- ◆ Single (x1) PCI Express Lane
- ◆ 32-bit/66 MHz PCI Interface
- ◆ Supports Both Forward- and Reverse-Mode PCI Express to PCI Bridging

Other Features

- ◆ Large 8KB Internal FIFO
- ◆ 128 byte maximum PCI Express payload size
- ◆ 3.3V I/O and 5V tolerant PCI
- ◆ PCI Express Flow Control Buffering
- ◆ Eight (8) outstanding PCI Express Transactions
- ◆ Completely integrated PCI Express PHY
- ◆ External EEPROM configuration option
- ◆ Four (4) GPIO pins for maximum design flexibility
- ◆ JTAG
- ◆ External arbiter or internal programmable arbitration for up to four bus masters
- ◆ Option to provide PCI clock
- ◆ Supports PCI and Virtual Interrupts (MSI)
- ◆ Lead-free packaging also available

Application:

PCI Express Sound Cards

PLX Product:

PEX 8111 – x1 PCIe-to-PCI Bridge

Key Benefit:

Easy Upgrade to PCI Express

PCI based Audio Controller Silicon

All sound cards in the market today ship as PCI add-in cards. This is largely due to the fact that audio controller silicon is a PCI native solution. This is slowly becoming a problem as PCIe slots are now widely available on the motherboards that are now shipping. Eventually, PCIe will be the dominant choice and sound cards will thus need to be available as a PCIe based add-in card. Nevertheless, it is very expensive and a lengthy process to design a PCIe native audio controller silicon. Sound card manufacturers need to address this issue to keep up with the new PCIe systems in the market today.



A PCI to PCIe Bridge solves the problem



The simple addition of the ExpressLane™ PEX 8111 will quickly solve this problem. The PEX 8111 supports up to a 66MHz 32-Bit PCI bus and converts it to a single x1 lane of PCI Express in Forward Mode. Sound card manufacturers do not have to wait for PCIe native audio controller silicon to become available since it is opportunities like this that the PEX 8111 was built for. The PEX 8111 has the capability to transition any PCI solution into a PCIe solution giving manufactures the flexibility to prepare for the PCIe filled motherboards that are now shipping.

The addition of the PEX 8111 requires only 1 square centimeter of additional board real estate to convert the PCI interface to a single x1 lane PCIe. In addition, the bridge only draws 400 milliwatts of additional power. The small footprint, low power consumption and low cost of the PEX 8111 make it an ideal fit for this application.

PCIe native Sound card

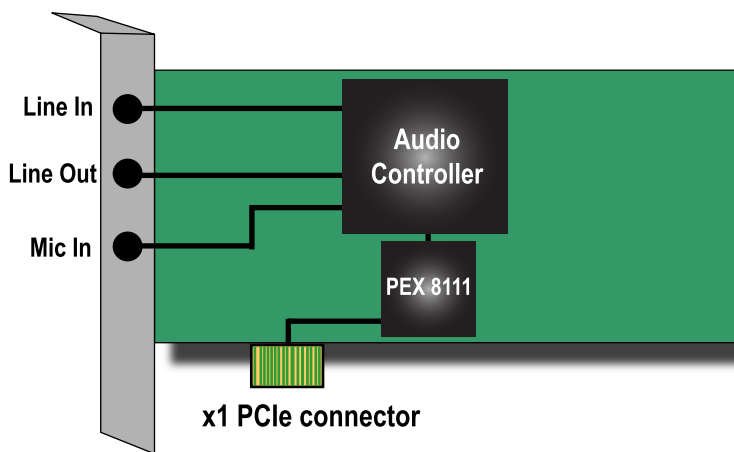

Shipping NOW!

The PEX 8111 is in production today and samples are in stock at PLX. In addition, Rapid Development Kits (RDK) boards are in stock. These boards allow a quick evaluation of your design concept without having to lay out your own board.

The PEX 8111RDK offers a known, working hardware environment. For example, you can take your existing PCI Card and plug it into this card to prove out the concept. The RDK will be able to plug into a PCI Express socket with your card on the other side of the bridge. RDK boards are available for both forward and reverse mode operation.

Key Advantage of using PLX

PLX is the industry's leading supplier of PCI Express Bridges and Switches. The company is focused on the design and support of silicon in the first wave of PCI Express systems. Below is a table showcasing the PCIe bridges that are available today:

PCIe Bridges	Lanes	Description
PEX 8111	x1	PCI-to-PCIe
PEX 8114	x4	PCI-X-to-PCIe
PEX 8311	x1	Local bus to PCIe

PLX also offers a PCI Bus to USB 2.0 Bridge chip that converts PCI native devices into a USB solution.

Design Tools & Documentation:

On PLX Public ToolBox:

http://www.plxtech.com/products/pci_express/PEX8111/default.asp

- ◆ Data Book, Product Brief, IBIS Models, HSPICE Models, BSDL Files

Contact Information

PLX Technology, Inc.
 870 Maude Ave.
 Sunnyvale, CA 94085 USA
 Tel: 1-408-774-9060
 Applications Support: Local FAE
 Product Marketing:
 Eugene Cabanban
ecabanban@plxtech.com
 Web Site: www.plxtech.com

© 2006 PLX Technology, Inc. All rights reserved. PLX and the PLX logo are registered trademarks of PLX Technology, Inc. ExpressLane, PowerDrive and the PowerDrive logo are trademarks of PLX Technology, Inc., which may be registered in some jurisdiction. All other product names that appear in this material are for identification purposes only and are acknowledged to be trademarks or registered trademarks of their respective companies. Information supplied by PLX is believed to be accurate and reliable, but PLX Technology, Inc. assumes no responsibility for any errors that may appear in this material. PLX Technology, Inc. reserves the right, without notice, to make changes in product design or specification.

8111-Audio-EA-1.0